



PRE-HEATER 628

S.M.D. Rework & BGA Re-balling System

Operating Manual

Thank you for choosing XYTRONIC Pre-heater 628. This appliance is specially designed for S.M.D. rework and also very convenient for re-balling BGA components. When used in conjunction with our 626 Hot Air rework system, the 628 Pre-heater will achieve marked improvements in quality and efficiency of S.M.D. rework operations.

Please read the operating manual carefully to maximize the advantages of using your new 628 Pre-heater and keep this manual readily accessible for reference.

C a t a l o g u e

- Warning & Caution P1
- Packing List and Specifications P2
- Part Names and Preparation P3
- Operation P3
- P.I.D. Temperature Controlled Operating Procedures P4
- PC board pre-heat vs. P.I.D. temperature table P5
- Exploded drawing P6
- Spare parts list P7
- Wiring Diagram P8
- How to replace the heater assembly P9
- Trouble shooting P10



! : [WARNING] and [CAUTION]



: [ELECTRICAL SHOCK]

Warning and caution are positioned at critical points in the manual to draw the user's attention to significant safety concerns. Be sure to comply with the following warnings and cautions for your safety.

1. Ensure the working voltage of the unit is the same as that of your electrical supply prior to use.
2. Check carefully of any damage during transportation.
3. Put the products on a safe and stable working table. Table surface should be consisted of fire and heat resistant material due to the fact that this unit can reach very high temperatures and potentially dangerous.
4. During the operation, the heater is extremely hot, and will cause serious burns if allowed to contact the skin. Use gloves and/or any heat resistant tools to pick up the PCB assembly to minimize the danger of burns.
5. Do not use the product near combustible gases or flammable materials.
6. Turn the power switch OFF and allow the heater to cool before checking or replacing heater and other parts, or prior to storing the unit.
7. This unit is designed for SMD rework, BGA re-balling and pre-heating PCB assembly. Please only use for intended applications.
8. Turn the power switch off and remove the AC power cord by pulling the plug (not the power cord) when the unit will remain unused for a longer period of time.
9. Keep this unit and all industrial tools out of the reach of children. Young Children should be supervised to ensure that they do not play with the appliance.

To prevent electrical shock, be sure to take the following precautions:

1. Make sure the unit is grounded. Always connect power to a grounded receptacle.
2. Do not pressure the AC power cord. Be sure the work area is well ventilated.
3. Do not bump, hit, pour water/liquids or otherwise subject the heating surface to physical shock..
This may damage the infrared ceramic heater assembly.
4. Do not modify the unit.
5. Do not expose the unit to moisture nor use the unit with wet hands.
6. Remove AC power cord by pulling the plug – not the cable.

Packing List

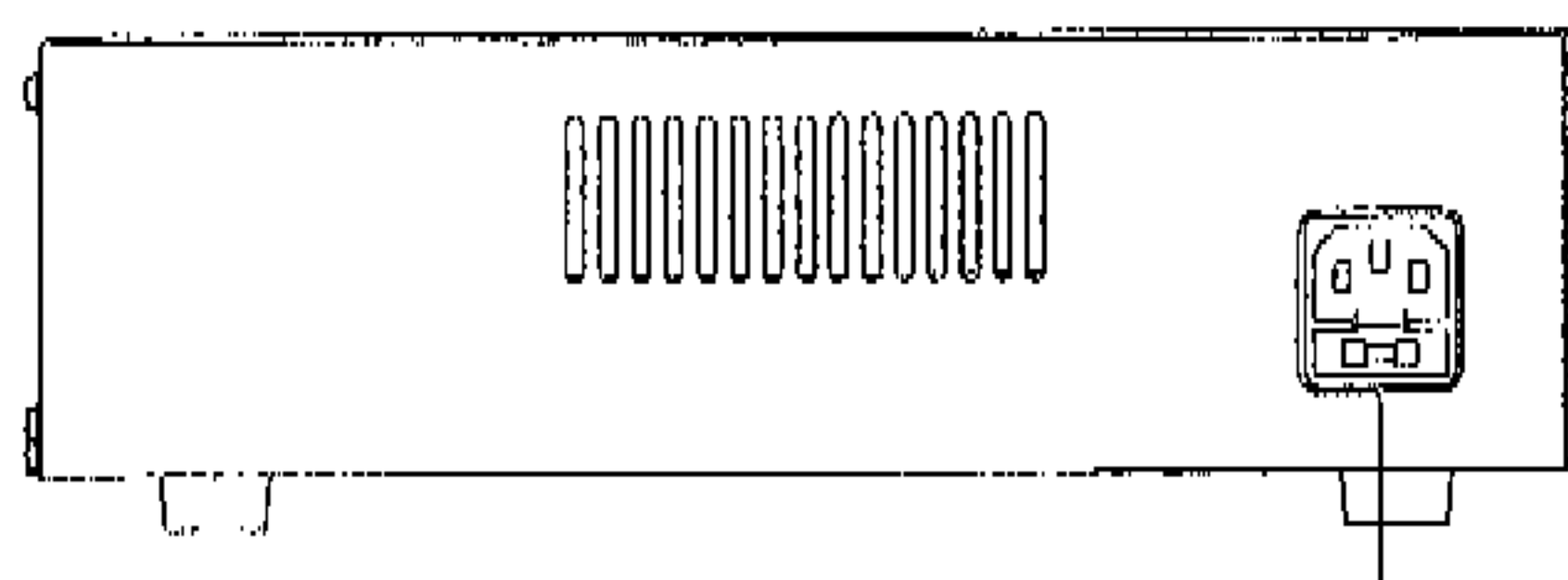
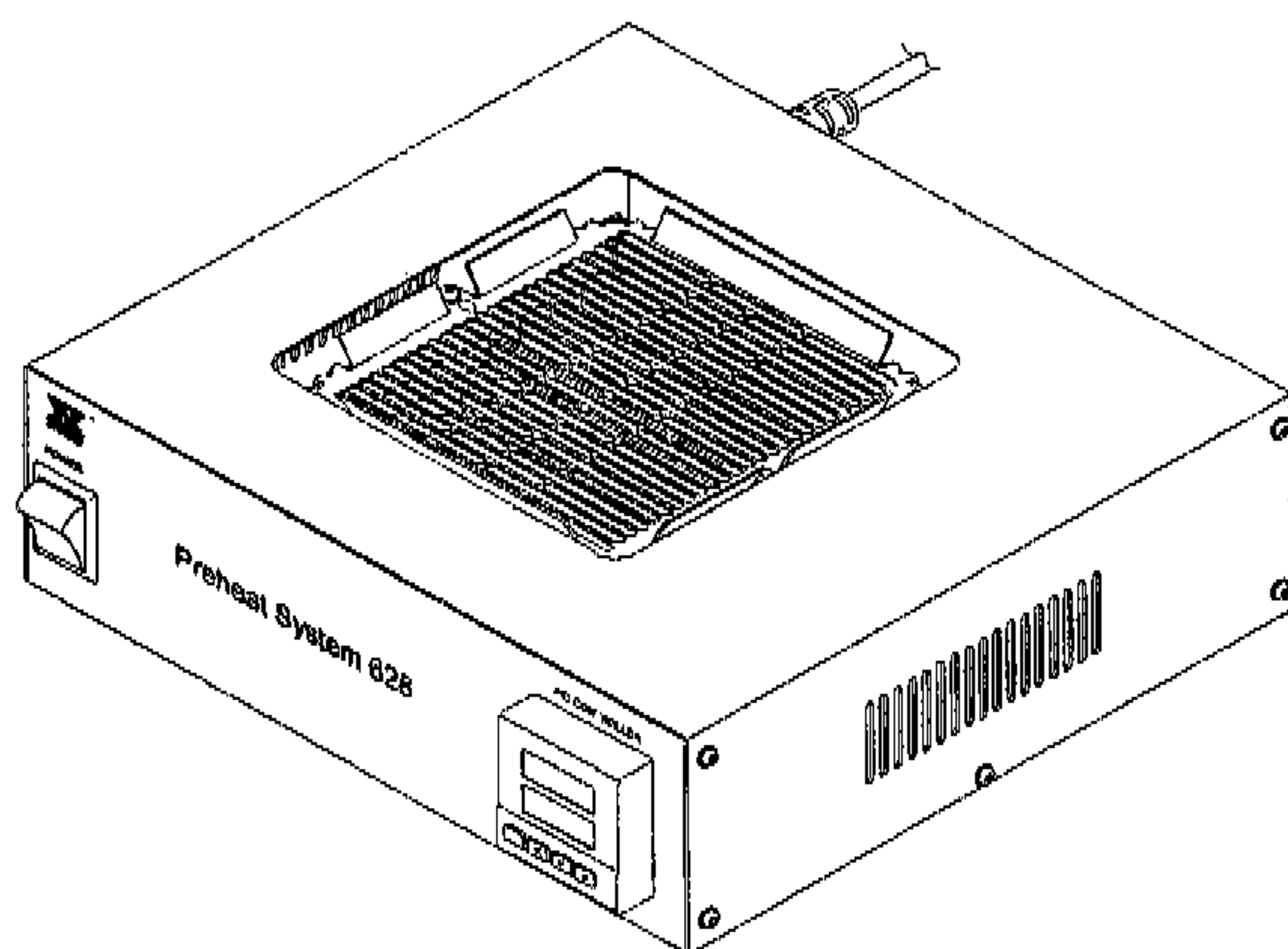

Power inlet with
fuse holder

Specifications

Model No.	628
Power Consumption	110V/500W : 230V/500W
Fuse	Delay Type , 110V : T5A ; 230V : T2.5A
Temperature	300°C (572°F) Max.
Dimensions	280(W)x255(D)x80(H), mm 11(W)x10.1(D)x3.15(H), inches
Weight (w/cord)	2.5kgs (5.5 lbs)

PART NAMES

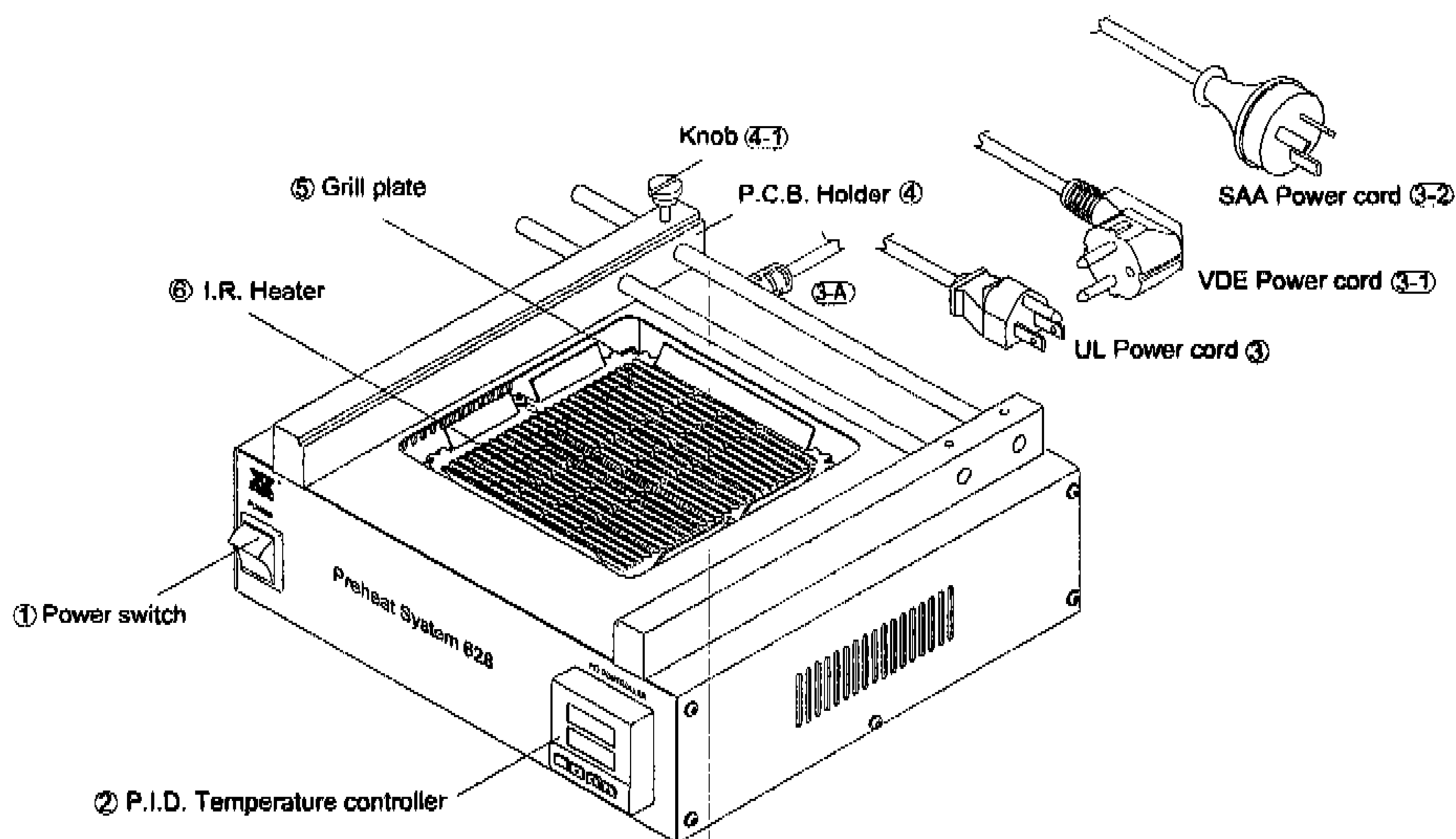

PREPARATION

ASSEMBLY AND ELECTRICAL CONNECTION

Accessories: AC power cord with plug, P.C. board holder, Grill plate, Instruction.

OPERATION

1. Flip the "Power switch ① on " OFF " position.
2. Insert the female plug ③-A in to the AC power receptacle on the back of the unit.
3. Plug the AC power cord ③ and flip the mains illuminated switch ① to the " ON " position.
4. P.I.D. ② will be self-checking for about 10 sec then you may pre-set the temperature.
5. Pre-set procedure please see P. 4 **P.I.D. TEMPERATURE CONTROLLER OPERATING PROCEDURE.**
6. Pre-heat temperature setting: Please refer P. 5. **PC board assembly pre-heat vs. P.I.D. temperature table.**
7. P.C.B. assembly positioning:
 - a. PCB < 130x130mm(5.12x5.12 inch) put on the grill plate ⑤.
 - b. PCB > 130x130mm(5.12x5.12 inch) put on the PCB holder assembly ④.
 - c. Adjustment of PCB holder : Turn loose the fixing knob ④-1 anti-clockwise. Pull the bar parallel ④ to the distance of PCB size what you need then turn the fixing knob clockwise tightly.

P.I.D. TEMPERATURE CONTROLLER OPERATING PROCEDURE

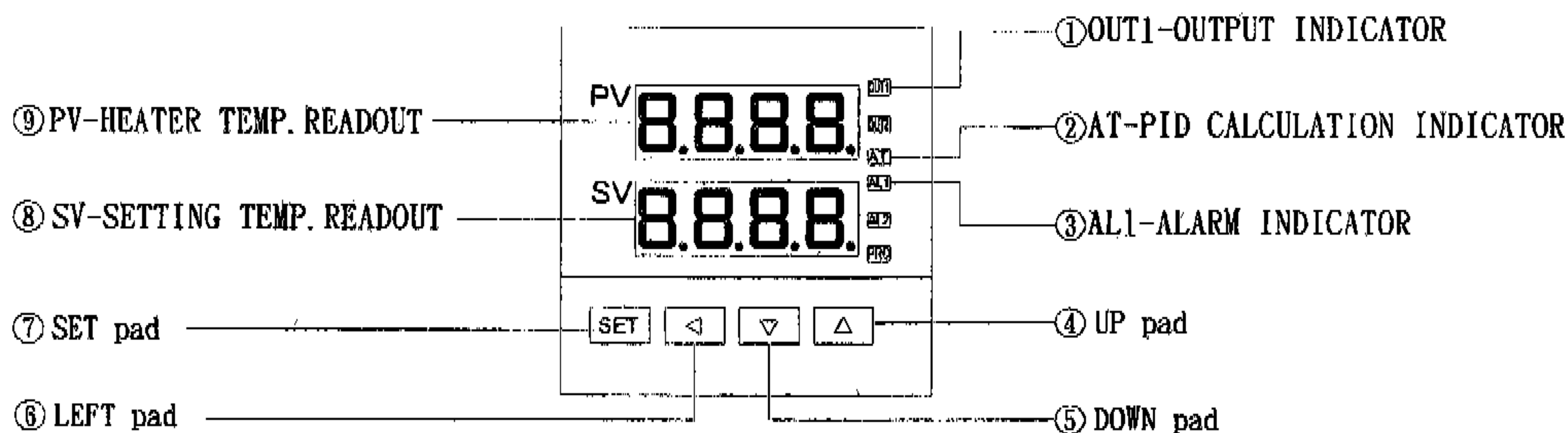

1. SELF-CHECKING (10sec.) for (a) PV/SV LED (b) K2/°C (or °F) (c) Temp. range 300°C (or 572°F) .

2. **【SETTING MODE】**: SV ⑧

(a) Depress the ◀ pad ⑥, the numeral will flash from right side numeral first, set from the 1st

decimal point by ▲ pad ④ or ▼ pad ⑤ . When the desired number is set then depress the

SET pad ⑦ to fix (the numeral will stop flashing) .

(b) Use the same procedure for each decimal place .

3. **PID AUTOMATIC OPERATION** : To maintain the accuracy and stability of heater's actual temperature,

Each reset (step#2. above) should be followed with an adjustment to the PID automatic calculator

through those steps :

(a) Depress SET pad ⑦, and the readout will show **【USER MODE】** PV / $\square\square$ (AT), SV / $\square\square$ (NO) .

(b) Depress ◀ pad ⑥, the SV/ $\square\square$ readout will flash, then depress ▲ pad ④ and revise NO ($\square\square$)

to YES (YES) . Depress SET pad ⑦ again, then the PID (AT) setting is completed (the AT lamp

② will remain lit until the automatic calculation operation is completed) .

(c) Depress SET pad ⑦ twice to **【USERS MODE】** when PID automatic operation(AT) is completed .

4. The OUT1 INDICATOR ① will be "ON" when the heater is heating and the AL1 alarm indicator ③

will be "ON" when the PV ⑨ temperature is reached to the temperature SV ⑧ .

PC board pre-heat vs. P.I.D. temperature table

Note: Let the heater temperature steady about 5 minutes before working.

Table 1

P.I.D. Setting	P.C.B. Temperature
150°C (302°F)	75°C (167°F)
200°C (392°F)	105°C (221°F)
250°C (482°F)	150°C (302°F)
300°C (572°F)	185°C (365°F)

P.C.B. put on the grill plate and leaves a 15mm space between PCB and infrared heater.

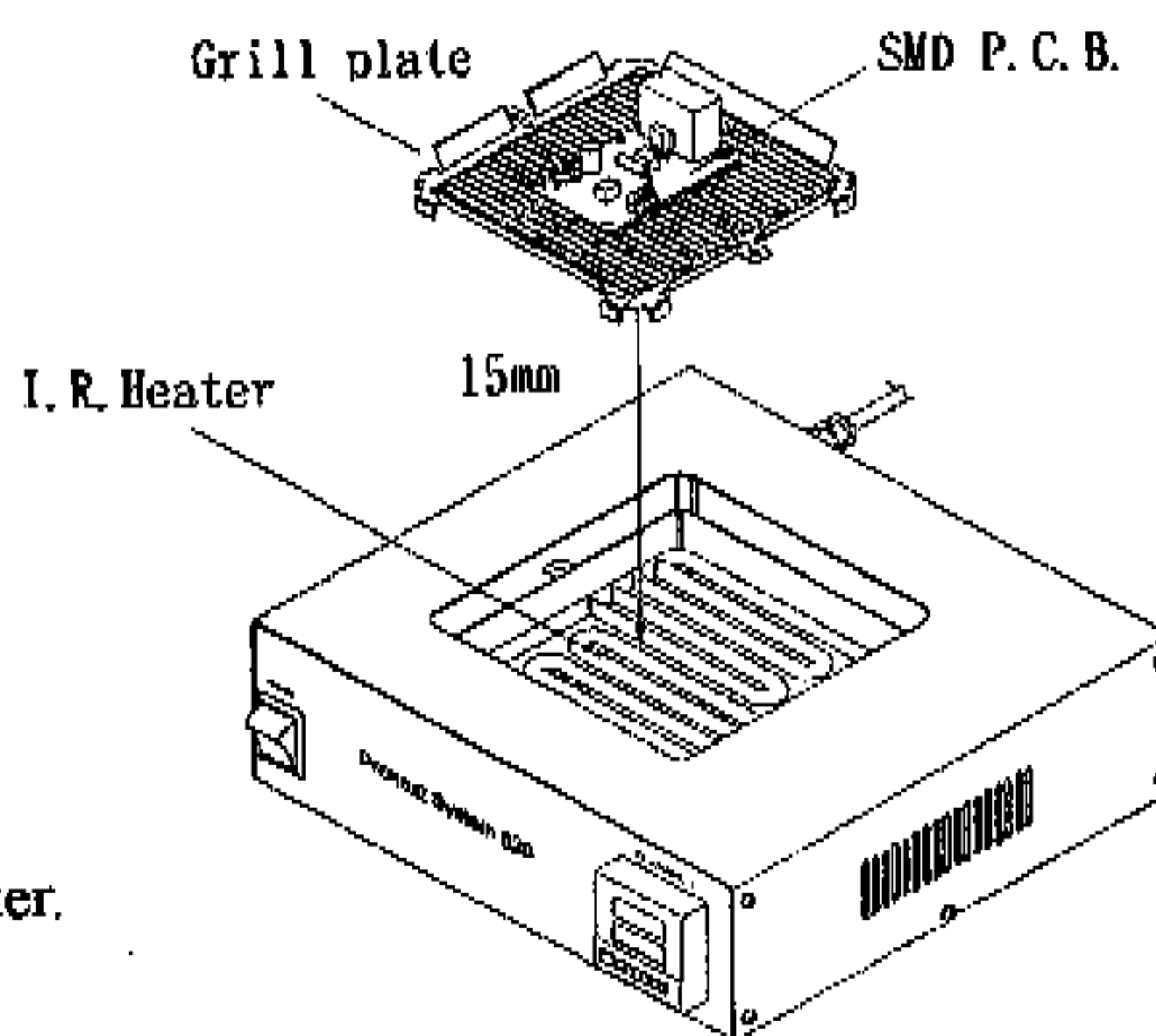

Fig. 1

CAUTION : To avoid burning your skin, do not touch the heater or PCB directly, please use clips or tweezers for pick up.

CAUTION : Do not allow water/liquids/solvents to touch the heater surface to avoid temperature drop cracks while the unit is still hot. Such cracks can lead to electrical shorts or failure of the heater.

Table 2

P.I.D. Setting	P.C.B. Temperature
150°C (302°F)	60°C (140°F)
200°C (392°F)	100°C (212°F)
250°C (482°F)	125°C (257°F)
300°C (572°F)	150°C (302°F)

P.C.B. put on the PCB holder and leave a 45mm space between PCB and infrared heater.

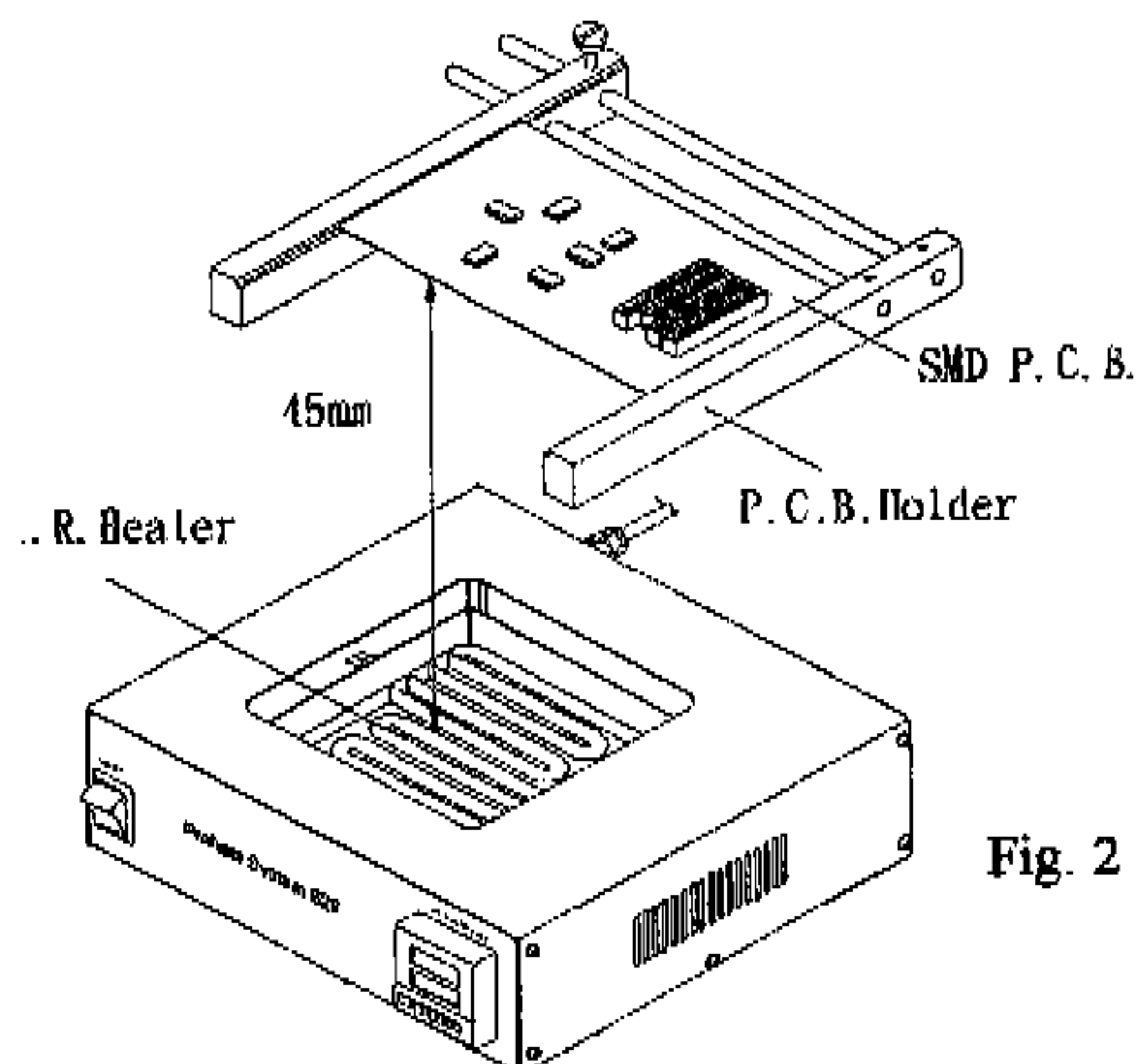
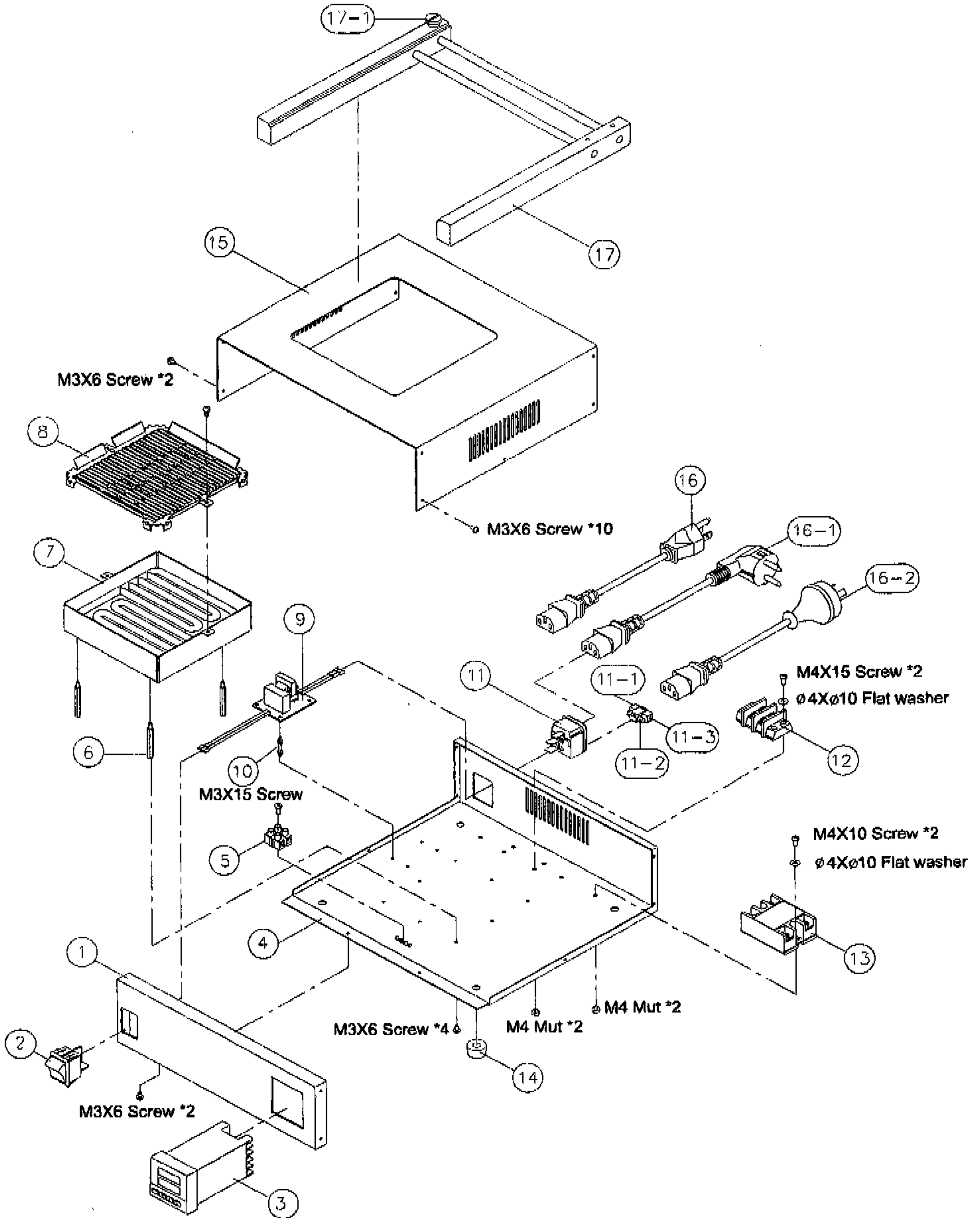

Fig. 2

CAUTION : Do not touch the PCB holder to avoid burning your skin during preheat!

628 EXPLODED DRAWING



628 SPARE PARTS LIST

Item	Part No.	Description
1	28-010225	Front panel
2	53-042241-300	DPST illuminated rocker switch, 4Pin
3	74-348482	PID Temperature controller
4	28-010215	Bottom housing
5	54-321322-2022	VDE Terminal block , 2Pole
6	42-040061	Copper post , M3 × 35mm
7	79A450042N	I.R. Heater assembly , 110V / 500W
	79A550042N	I.R. Heater assembly , 230V / 500W
8	29-010101	Grill plate
9	B628CNE	EMI PCB assembly
10	26-050170-09	Spacer support , LCA-10
11	58-3030221	Power inlet with fuse holder
11-1		Fuse box
11-2,3	62-205002-205	Delay type , T5A / 20mm for 110V
	62-202502-205	Delay type , T2.5A / 20mm for 230V
12	54-344523-3010	Bakelite Terminal block , 2Pole
13	21-3845	Solid State Relay (SSR) , SSR-25 DA
14	52-020034-01	Rubber foot
15	28-010235	Top housing
16	33-120318-181	UL AC Power cord w/plug , SVT type
16-1	33-330519-181	VDE AC Power cord w/plug , H05VV-F type
16-2	33-670621	SAA AC Power cord w/plug , H05VV-F type
17	29A010081	P.C.B. holder assembly
17-1	26-0107241	Fixing knob , M4 × 13mm

628 WIRING DIAGRAM

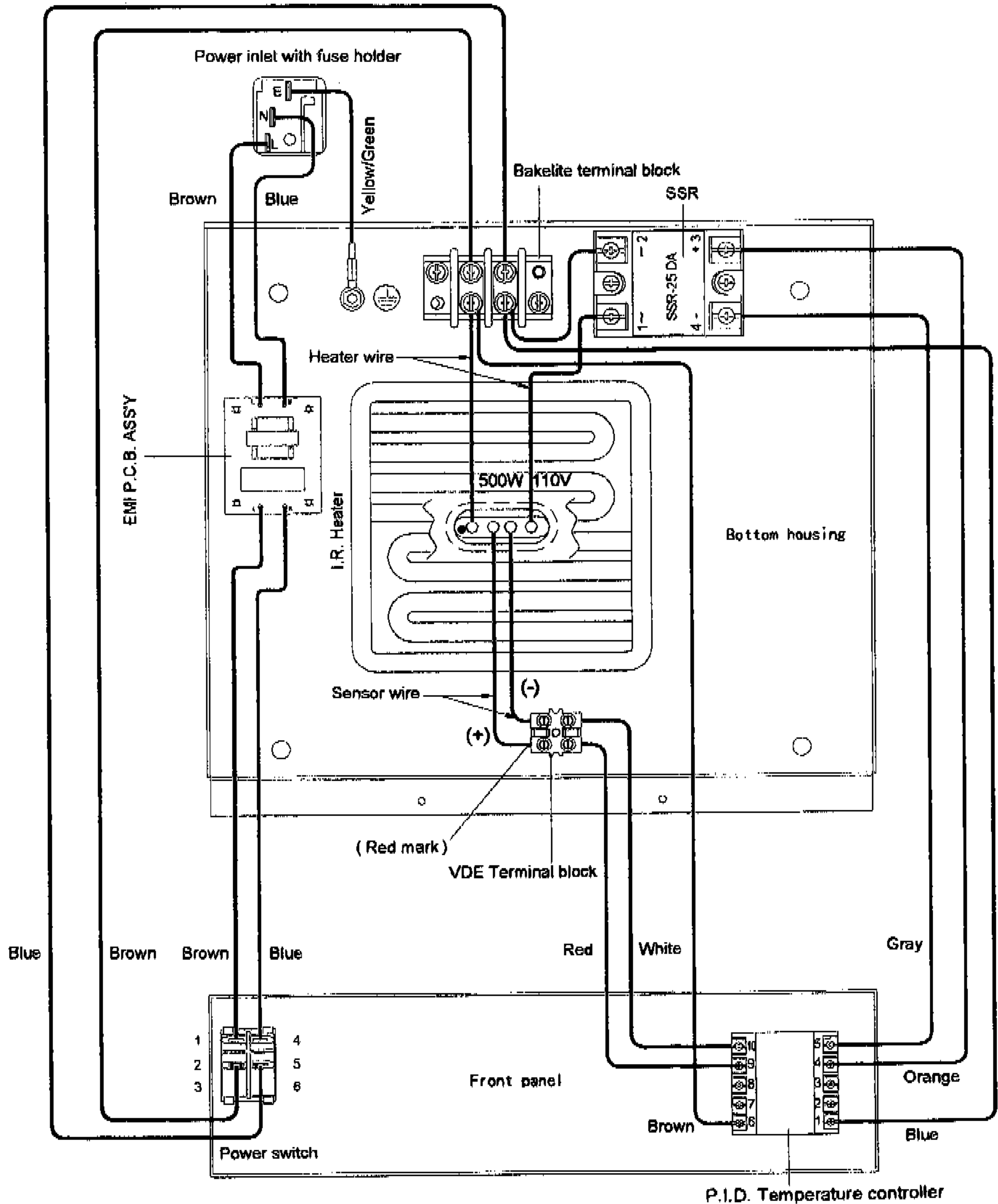

How to replace the heater assembly

Disassembly of heating element

- A. Disconnect the 10pcs of M3*6 screws on the both side of top housing.
- B. Disconnect the ① & ② screws, loose the ③ & ④ screws on the bottom housing and the lead wires of the heating element can be taken out. Disconnect the (a), (b), (c), & (d) four screws from the rear side of the bottom enclosure then the ceramic heater with frame can be taken out.
- C. Disconnect the grill plate ⑤ & 4 posts ⑥, and replace with a new heater assembly.

Assembly of heating element

- a) Re-assemble the heater in reverse according to the procedure of above C/B/A.

Note : Do not misconnect the ④(+), ③(-) sensor wire. Sensor (+) has a **Red mark** to be connected with 9pin red wire of the P.I.D. Temperature controller.

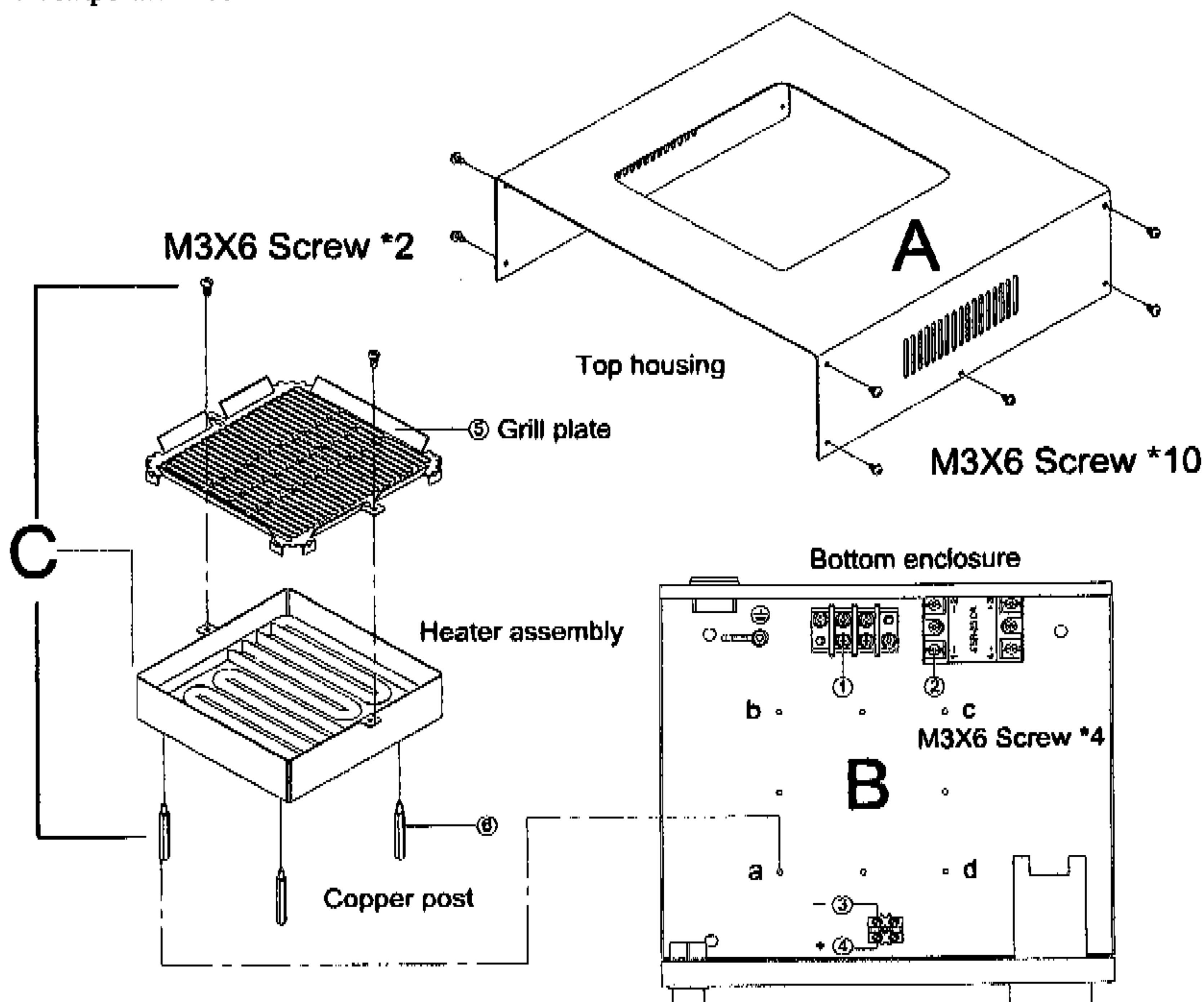
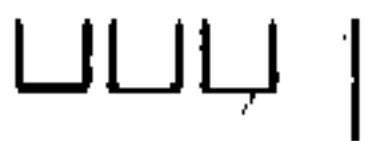

Fig. 3



TROUBLE SHOOTING

WARNING :

1. Unless otherwise directed, carry out these procedures with the power switch OFF and the power UNPLUGGED before the trouble is cleared.
2. If the unit is damaged, it should be repaired by the manufacturer or its authorized repairing centers to preclude damage to either the unit or injury to personnel.
3. Be sure the unit has been cooled to room temperature before beginning work.

Item	Problem	Remedy
1. No Power when Power switch ON.	a. Check the AC power cord and receptacle. b. Mains switch no good. c. Fuse blown out.	1. Re-insert the plug. 2. Replace the switch. 3. Investigate why the fuse blew then replace a New fuse. (If the cause can not be determined, just replace The fuse. If the fuse blows again, send the unit To repair.)
2. Heater no temperature When mains switch is in "ON" position.	a. Heater open. b. SSR no function (SSR LED no light) c. P.I.D. controller no function (4/5 Terminal has no DC output)	1. Replace the heater assembly. 2. Check P.I.D. output. If SSR (3) & (4) has DC Input voltage, then replace SSR. 3. Replace new P.I.D.
3. PV readout 	a. Sensor open. b. Polarity in reverse.	1. Replace a new heater if sensor broken. 2. Reconnect.
4. PV readout 	Temperature > 300°C setting range.	Actual temperature > 300°C is normal.
5. PV readout 	Temperature < 0°C setting range.	Room temperature < 0°C will become normal after Warming up.

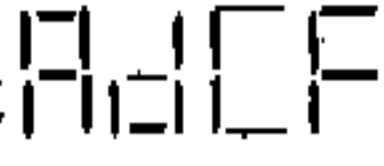
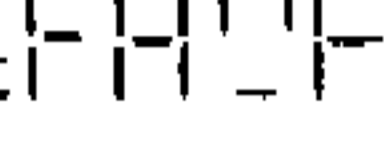
Item	Problem	Remedy
6. PV readout 	P.I.D. self-calculation in-effect.	Change the setting by manual mode.
7. PV readout 	A/D reverse out of control.	Replace new P.I.D.
8. PV readout 	Memory in-effect	Replace new P.I.D.

Note : Heater resistance value 110V / 23.5 Ω , 230V / 106 Ω ; Sensor : 0.7-1 Ω .

ITEM 2. HEATER NO TEMPERATURE MEASURES :

Fig. 4

